

REV.	DESCRIPTION	REV BY	DATE	REQUESTOR
A	NEW RELEASE (14332)	CHIN	140819	LLOYD
1	ADD AIR CHANNEL TO THE M.CLAMP LID	CHIN	200819	LLOYD
2	REVISE TO SKIP ONE DIE IN X-DIRECTION ; ENLARGE SOCKET SIZE	CHIN	260819	LLOYD
3	1) INCREASE OPENING FOR TWEEZER RELIEF IN ALPL 2) SEPARATE GND PAD INTO 2 PADS ON FOOTPRINT	TNG LH	270819	LLOYD

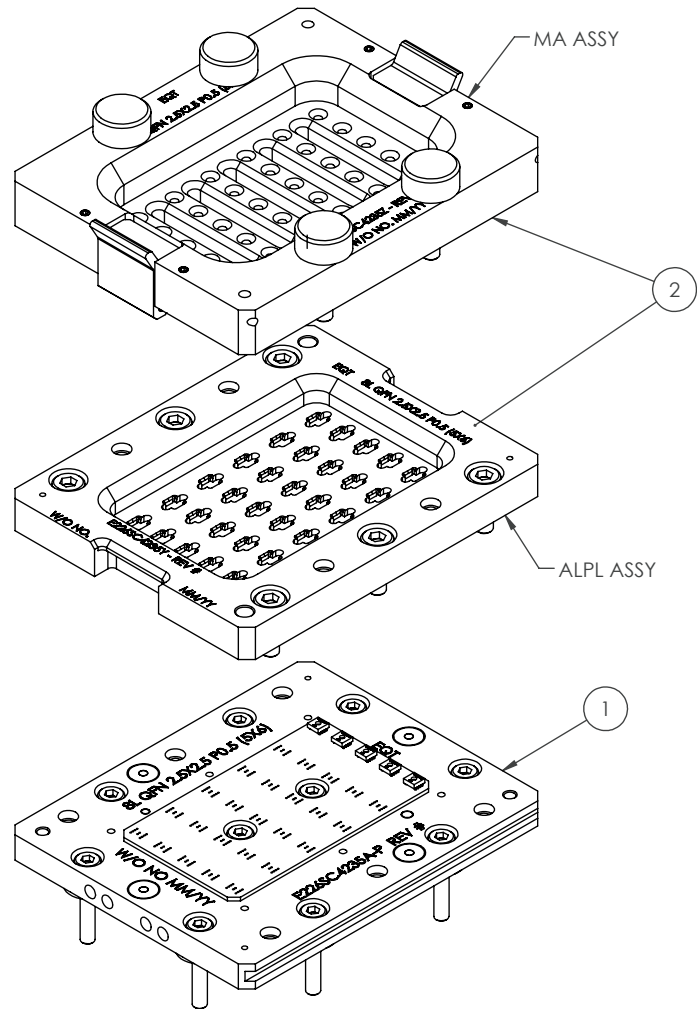

DEVICE (NON-TI)

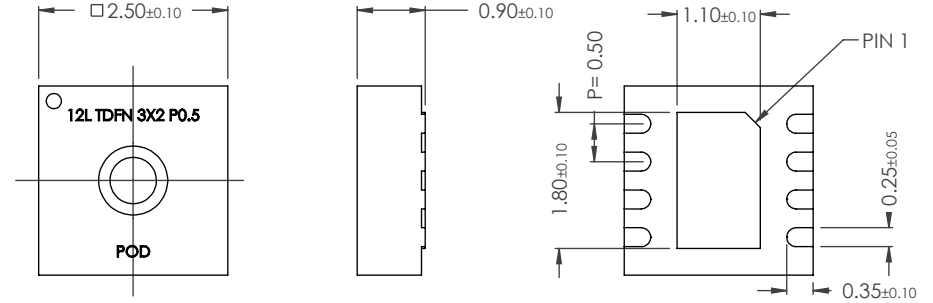

STRIP DEVICE

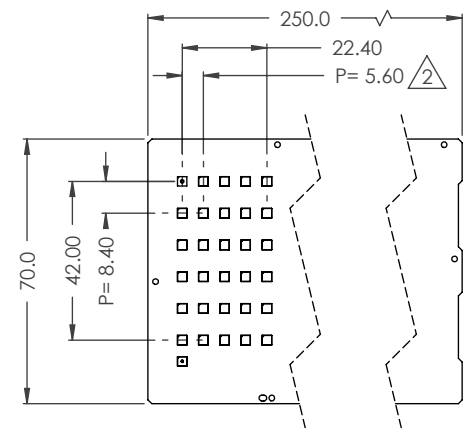

2	E226SC4235X	8L QFN 2.5X2.5 P0.5 STRIP (5x6) NK E-SERIES CONTACTOR, MA + ALPL ASSY	1	REFER BOM	-
1	E226SC4235A-P	8L QFN 2.5X2.5 P0.5 STRIP (5x6) NK E-SERIES CONTACTOR, ASSY	1	REFER BOM	-
ITEM	EQT DWG NO	DESCRIPTION	QTY.	MATERIAL	VENDOR

5. CONSULT SALES/CUSTOMER SERVICE/PROCUREMENT FOR DETAILS OF "W/O NO. MM/YY" ENGRAVING ENGRAVING DEPTH TO BE 0.5mm UNLESS OTHERWISE SPECIFIED
 4. ASK IF IN DOUBT
 3. ALL DIMENSIONS ARE AFTER FINISHING.
 2. NO BURRS AND SHARP EDGES ARE ALLOWED.
 1. DIMENSION WITH CONTROLLED TOLERANCE MUST BE CHECKED
- NOTES: UNLESS OTHERWISE SPECIFIED

PROPOSAL DRAWING

PROPRIETARY NOTICE
INFORMATION CONTAINED ON THIS DRAWING IS PROPERTY OF EQUIPTEST ENGINEERING PTE.LTD. AND MAY NOT BE COPIED, REPRODUCED NOR PARTS MADE WITHOUT PRIOR PERMISSION FROM EQUIPTEST ENGINEERING PTE.LTD.

PART NAME: **8L QFN 2.5X2.5 P0.5 STRIP (5x6) NK E-SERIES CONTACTOR, FULL ASSY**

PD RF NO.: **14332** DRAWING NO.: **E226SC4235-P** REV.: **A**

MATERIAL	REFER BOM	UNIT: mm	NAME	DATE
FINISH	-	MACHINED FINISH 0.8	TNG LH DRAWN	270819
UNLESS OTHERWISE SPECIFIED TOLERANCES ARE:	X ±0.5	EQUIPTEST ENGINEERING PTE. LTD.	CHIN CHECKED	270819
X.X ±0.1	ALAN APPROVED		270819	
X.XX ±0.05	REF NO.		-	
ANGULAR TOLERANCES	X ±1°	SIZE: A4	SCALE: N.T.S	SHEET: 1 OF 5
X.XX ±0.5°				

CONTACTOR ASSY

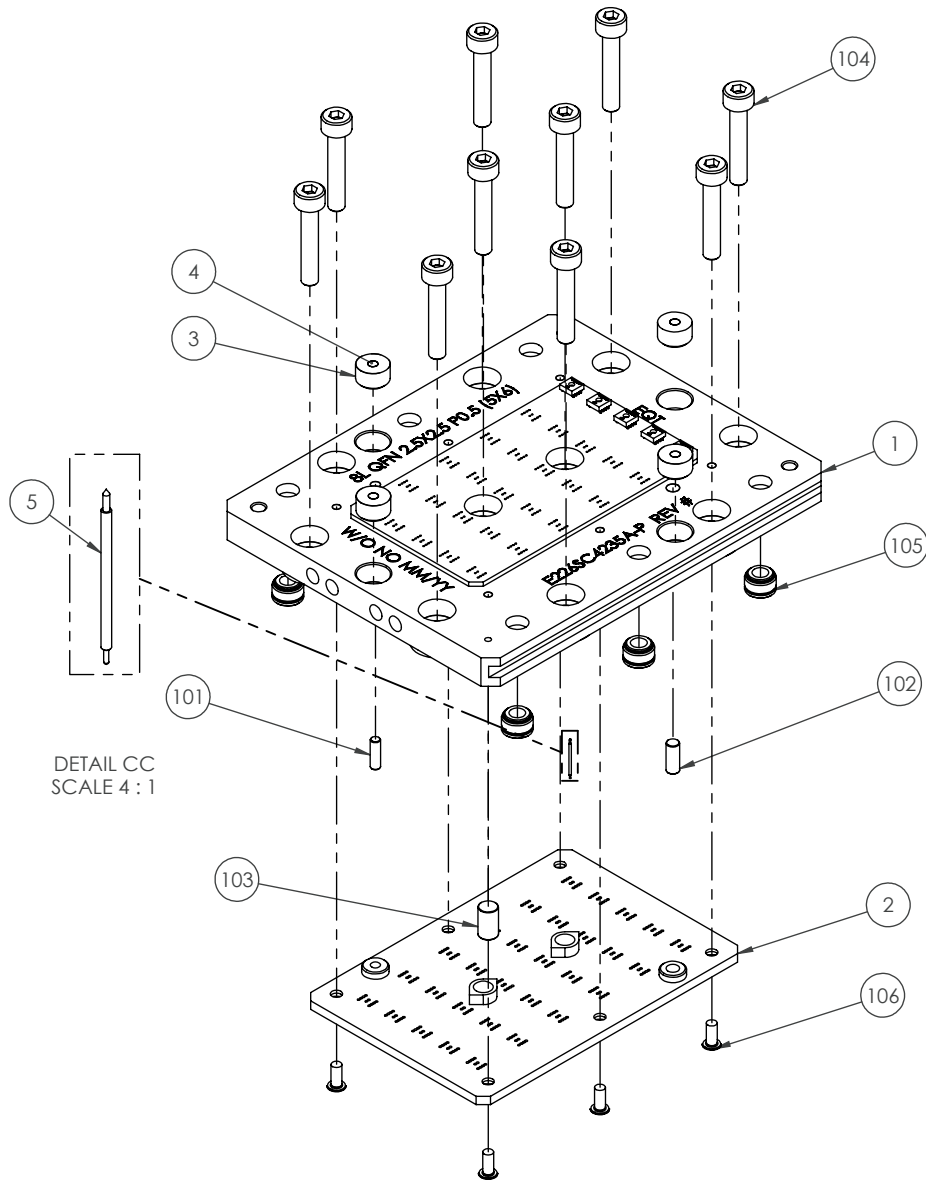

DETAIL CC
SCALE 4 : 1

5. CONSULT SALES/CUSTOMER SERVICE/PROCUREMENT FOR DETAILS OF "W/O NO. MM/YY" ENGRAVING ENGRAVING DEPTH TO BE 0.5mm UNLESS OTHERWISE SPECIFIED
4. ASK IF IN DOUBT
3. ALL DIMENSIONS ARE AFTER FINISHING.
2. NO BURRS AND SHARP EDGES ARE ALLOWED.
1. DIMENSION WITH CONTROLLED TOLERANCE MUST BE CHECKED

NOTES: UNLESS OTHERWISE SPECIFIED

PROPOSAL DRAWING

106	B-F18A01X4SZ	THIN HEAD PHILLIPS SCREW M1.6 x L 4	6	STEEL ZINC	-
105	B-F10B04X3BR	BRASS INSERT M3 x L 3	6	BRASS	
104	B-F01C03X14SS	SOCKET HEAD CAP SCREW M2.5 x L 14	10	SUS	S0178
103	B-D3X5SS	DOWEL PIN DIA 3 h8 x L 5	1	SUS	S0178
102	B-D2x5SS	DOWEL PIN DIA 2 x L 5	2	SUS	S0254
101	B-D1.5x5SS	DOWEL PIN DIA 1.5 x L 5	1	SUS	S0254
5	E05022391-AE-1	CONTACT PROBE	300	STD	-
4	E222SC2847K	48L LQFP 7X7 P0.5 MCT SH5000 9X5 CONTACTOR ASSY, FIDUCIAL PIN	4	CERAMIC PEEK	-
3	E147SC1870M	192X 8L SOIC MATRIX CONTACTOR-FIDUCIAL BIG	4	DERLIN BLACK	-
2	E226SC4235C	8L QFN 2.5X2.5 P0.5 STRIP (5x6) NK E-SERIES CONTACTOR, COVER	1	PI	-
1	E226SC4235B	8L QFN 2.5X2.5 P0.5 STRIP (5x6) NK E-SERIES CONTACTOR, BODY	1	PI	-
ITEM	EQT DWG NO	DESCRIPTION	QTY.	MATERIAL	VENDOR

<small>PROPRIETARY NOTICE INFORMATION CONTAINED ON THIS DRAWING IS PROPERTY OF EQUIPTEST ENGINEERING PTE LTD. AND MAY NOT BE COPIED, REPRODUCED NOR PARTS MADE WITHOUT PRIOR PERMISSION FROM EQUIPTEST ENGINEERING PTE LTD</small>		PART NAME		8L QFN 2.5X2.5 P0.5 STRIP (5x6) NK E-SERIES CONTACTOR, FULL ASSY	
MATERIAL		PDRF NO.		DRAWING NO.	
FINISH		14332		E226SC4235-P	
UNLESS OTHERWISE SPECIFIED TOLERANCES ARE: X ±0.5 X.X ±0.1 X.XX ±0.05 ANGULAR TOLERANCES X ±1° X.X ±0.5°		UNIT: mm		REV. A	
MACHINED FINISH 0.8		NAME		DATE	
 EQUIPTEST ENGINEERING PTE. LTD.		TNG LH DRAWN		270819	
SIZE A4		SCALE N.T.S		SHEET 2 OF 5	
REF NO.		-			

CONTACTOR ASSY

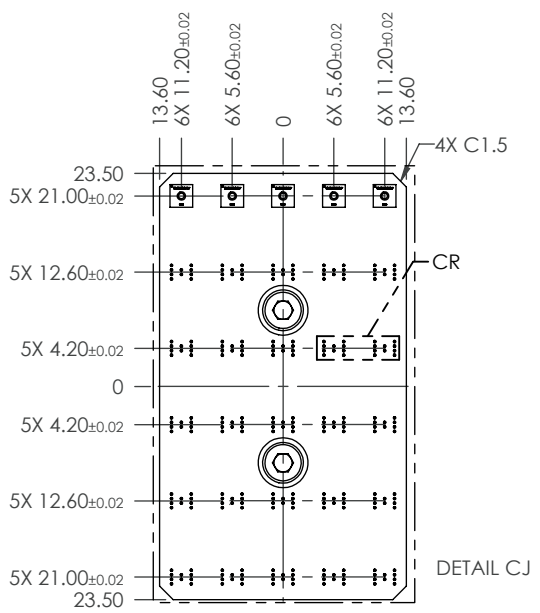
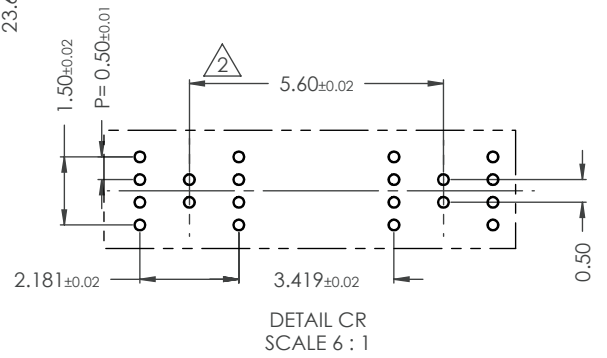
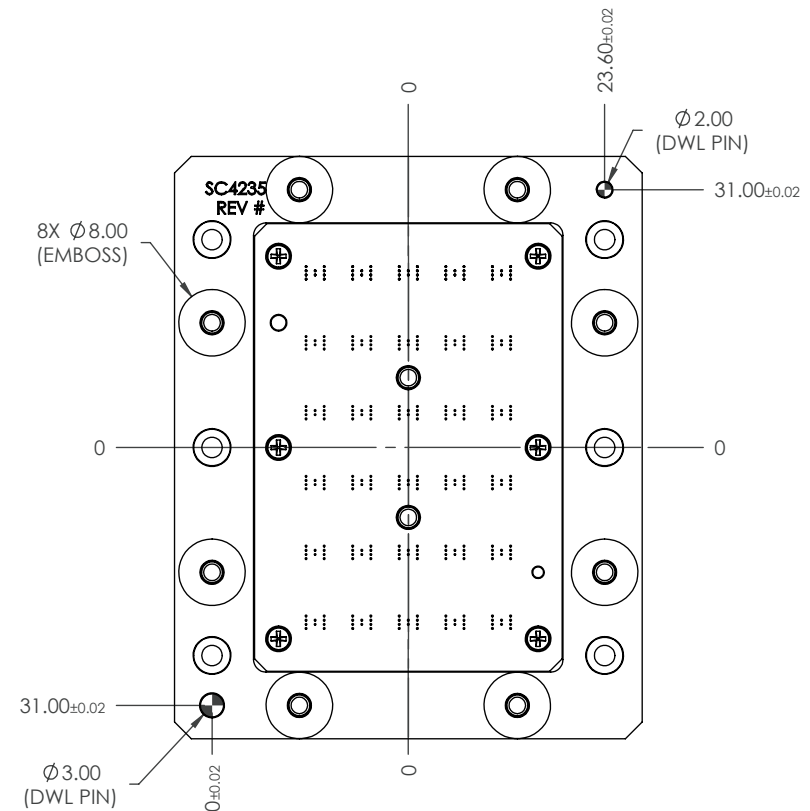
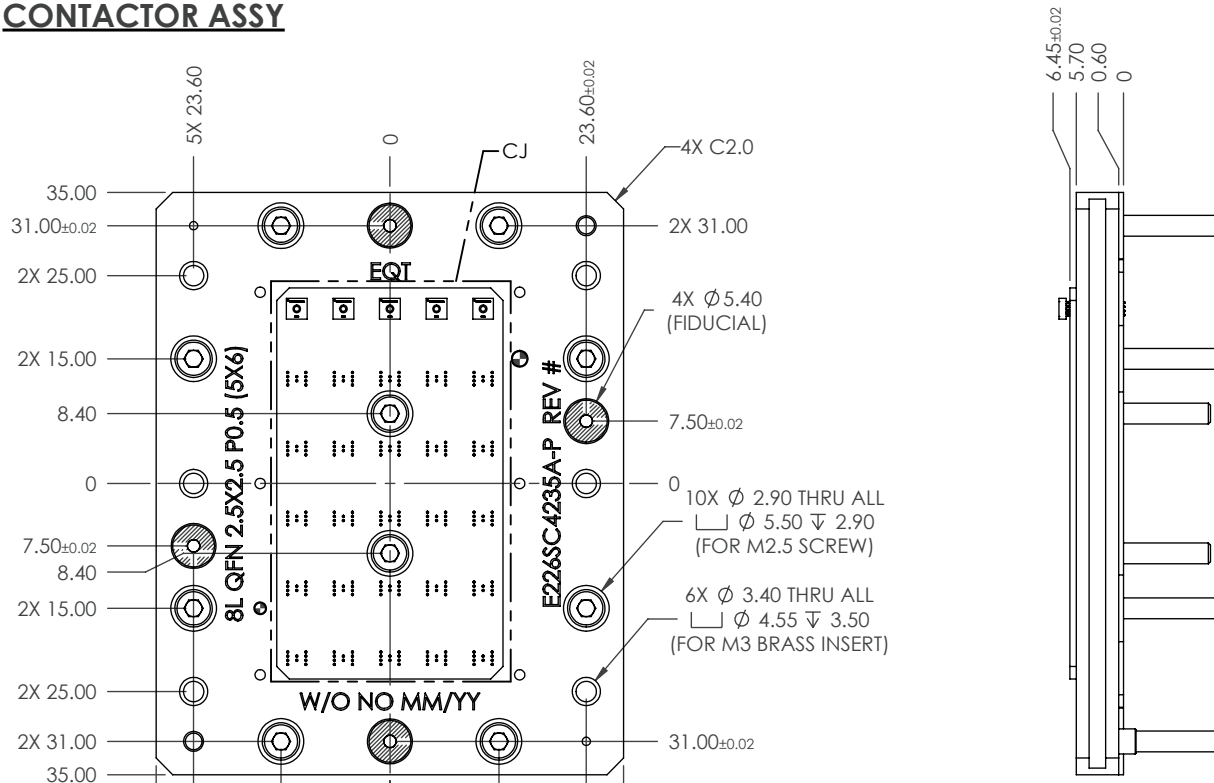

5. CONSULT SALES/CUSTOMER SERVICE/PROCUREMENT FOR DETAILS OF "W/O NO. MM/YY" ENGRAVING ENGRAVING DEPTH TO BE 0.5mm UNLESS OTHERWISE SPECIFIED
 4. ASK IF IN DOUBT
 3. ALL DIMENSIONS ARE AFTER FINISHING.
 2. NO BURRS AND SHARP EDGES ARE ALLOWED.
 1. DIMENSION WITH CONTROLLED TOLERANCE MUST BE CHECKED
- NOTES: UNLESS OTHERWISE SPECIFIED

PROPOSAL DRAWING

PROPRIETARY NOTICE INFORMATION CONTAINED ON THIS DRAWING IS PROPERTY OF EQUIPTEST ENGINEERING PTE LTD. AND MAY NOT BE COPIED, REPRODUCED NOR PARTS MADE WITHOUT PRIOR PERMISSION FROM EQUIPTEST ENGINEERING PTE LTD		PART NAME 8L QFN 2.5X2.5 P0.5 STRIP (5x6) NK E-SERIES CONTACTOR, FULL ASSY	
MATERIAL REFER BOM	FINISH -	PDRF NO. 14332	DRAWING NO. E226SC4235-P
UNLESS OTHERWISE SPECIFIED TOLERANCES ARE: X ±0.5 X.X ±0.1 X.XX ±0.05 ANGULAR TOLERANCES X ±1° X.X ±0.5°	UNIT : mm MACHINED FINISH 0.8	NAME EQUIPTEST ENGINEERING PTE. LTD.	DATE 270819
SIZE A4	SCALE N.T.S	SHEET 3 OF 5	REF NO. -

CONTACTOR WITH ALPL

CONTACTOR WITH M.CLAMP

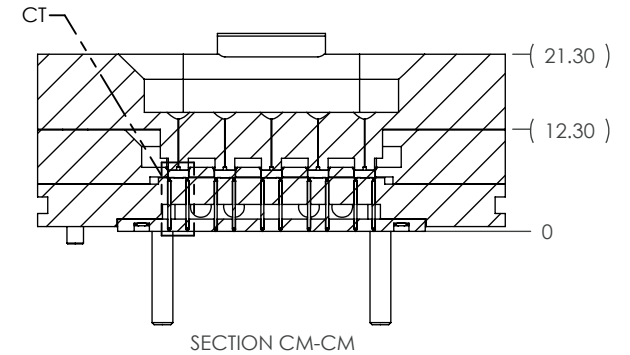
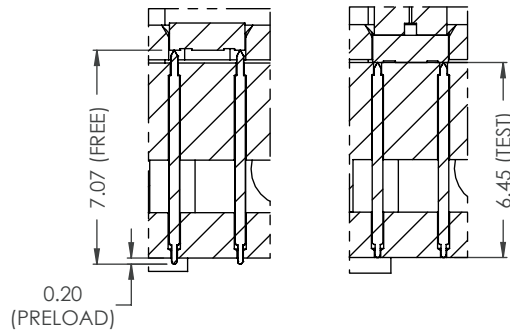
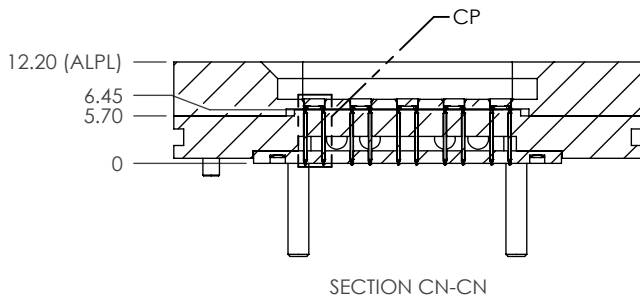
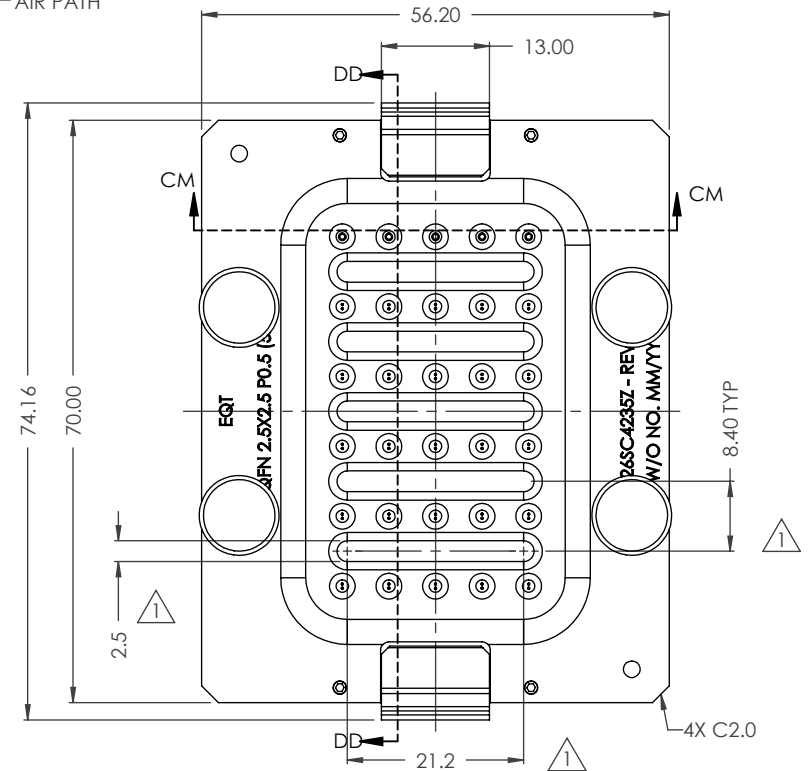
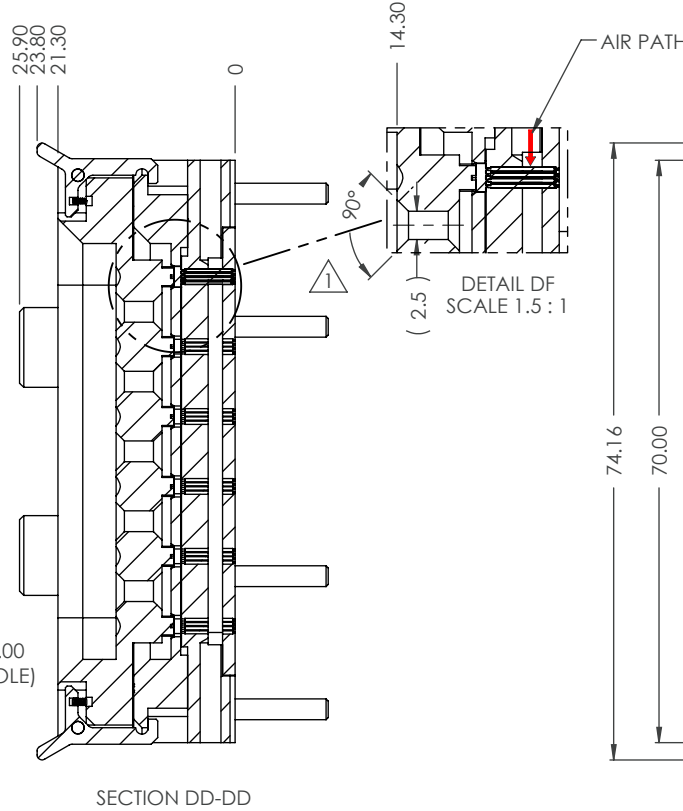
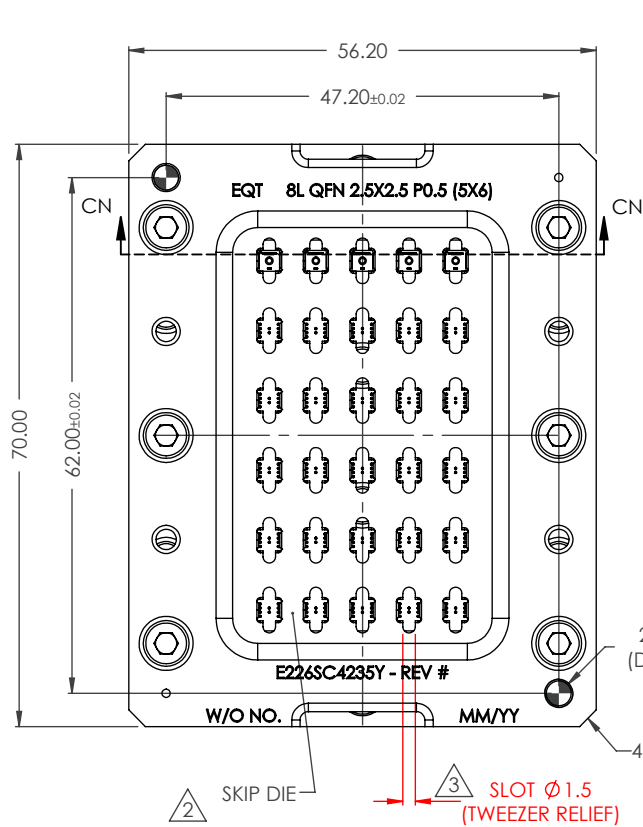

5. CONSULT SALES/CUSTOMER SERVICE/PROCUREMENT FOR DETAILS OF "W/O NO. MM/YY" ENGRAVING ENGRAVING DEPTH TO BE 0.5mm UNLESS OTHERWISE SPECIFIED
4. ASK IF IN DOUBT
3. ALL DIMENSIONS ARE AFTER FINISHING.
2. NO BURRS AND SHARP EDGES ARE ALLOWED.
1. DIMENSION WITH CONTROLLED TOLERANCE MUST BE CHECKED

NOTES: UNLESS OTHERWISE SPECIFIED

PROPOSAL DRAWING

PROPRIETARY NOTICE INFORMATION CONTAINED ON THIS DRAWING IS PROPERTY OF EQUIPTEST ENGINEERING PTE LTD. AND MAY NOT BE COPIED, REPRODUCED NOR PARTS MADE WITHOUT PRIOR PERMISSION FROM EQUIPTEST ENGINEERING PTE LTD.		PART NAME 8L QFN 2.5X2.5 P0.5 STRIP (5x6) NK E-SERIES CONTACTOR, FULL ASSY	
MATERIAL REFER BOM		PDRF NO. 14332	DRAWING NO. E226SC4235-P
FINISH -		UNIT : mm	NAME TNG LH
UNLESS OTHERWISE SPECIFIED TOLERANCES ARE: X ±0.5 X.X ±0.1 X.XX ±0.05 ANGULAR TOLERANCES X ±1° X.X ±0.5°		MACHINED FINISH 0.8	DATE 270819
SIZE A4		SCALE N.T.S	SHEET 4 OF 5
REF NO. -		DATE 270819	

FOOTPRINT

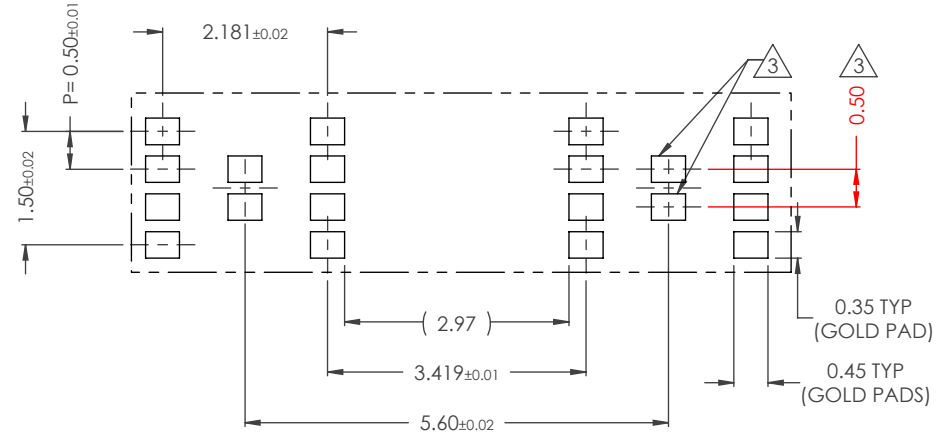
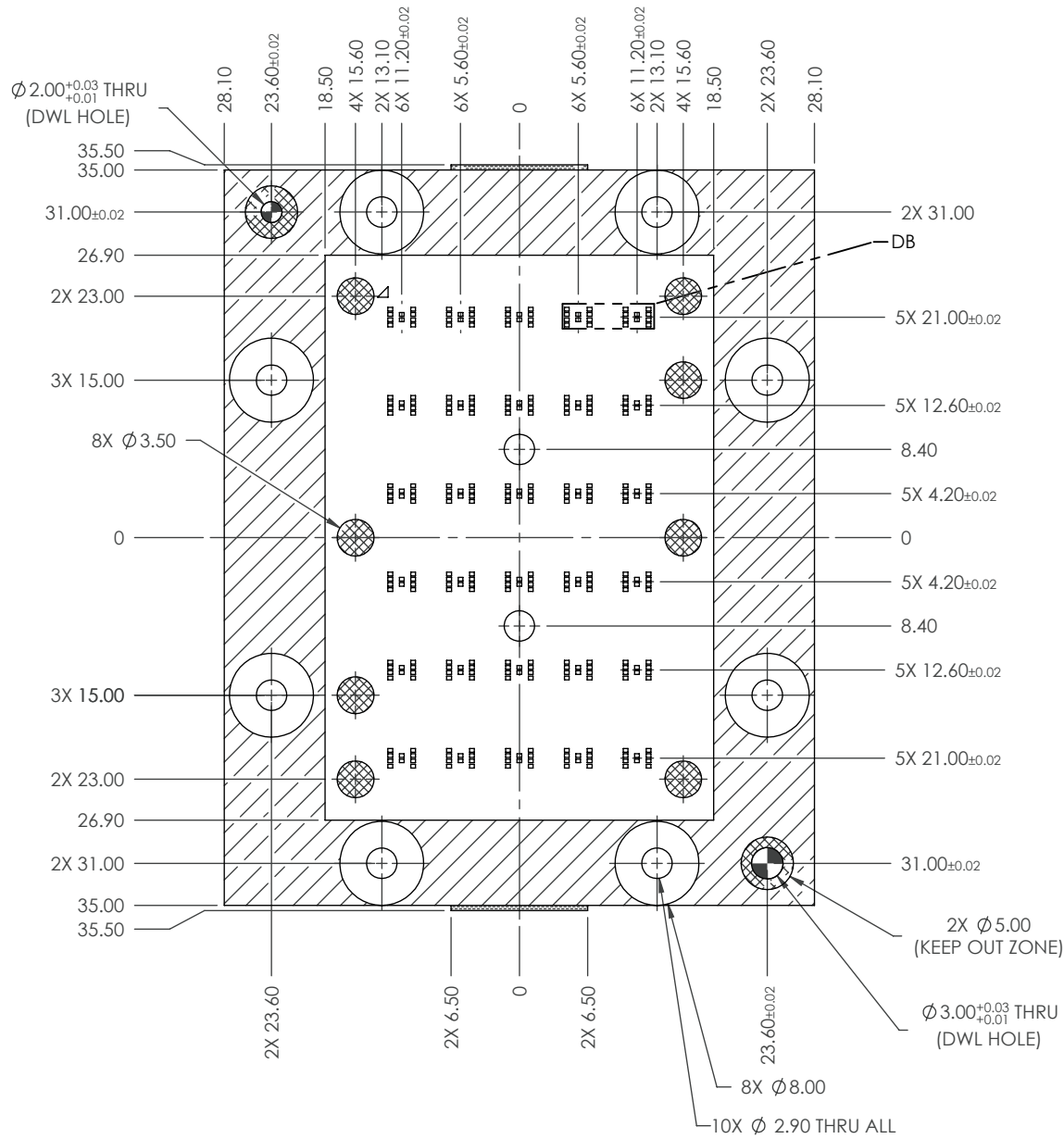

DETAIL DB
SCALE 10 : 1

5. CONSULT SALES/CUSTOMER SERVICE/PROCUREMENT FOR DETAILS OF "W/O NO. MM/YY" ENGRAVING ENGRAVING DEPTH TO BE 0.5mm UNLESS OTHERWISE SPECIFIED
4. ASK IF IN DOUBT
3. ALL DIMENSIONS ARE AFTER FINISHING.
2. NO BURRS AND SHARP EDGES ARE ALLOWED.
1. DIMENSION WITH CONTROLLED TOLERANCE MUST BE CHECKED

NOTES: UNLESS OTHERWISE SPECIFIED

PROPOSAL DRAWING

- CONTACTOR TOUCH DOWN ZONE - NO SOLDER TAILS, NO SOLDERMASK AND NO SILKSCREEN ALLOWED ON CONTACTOR SIDE OF BOARD. TRACES AND VIAS ALLOWED, HEIGHT NOT TO EXCEED HEIGHT OF PLATED PAD.
- COMPONENT ZONE - COMPONENT HEIGHT NOT TO EXCEED 0.50mm.
- COPPER KEEPOUT ZONE - NO COMPONENT TRACES, VIAS AND SOLDER TAILS ALLOWED.
- LATCH ZONE - COMPONENT HEIGHT NOT TO EXCEED 9.50mm.

<small>PROPRIETARY NOTICE INFORMATION CONTAINED ON THIS DRAWING IS PROPERTY OF EQUIPTTEST ENGINEERING PTE LTD. AND MAY NOT BE COPIED, REPRODUCED NOR PARTS MADE WITHOUT PRIOR PERMISSION FROM EQUIPTTEST ENGINEERING PTE LTD</small>		PART NAME		8L QFN 2.5X2.5 P0.5 STRIP (5x6) NK E-SERIES CONTACTOR, FULL ASSY	
		PDRF NO.	14332	DRAWING NO.	E226SC4235-P
MATERIAL	REFER BOM	 UNIT : mm MACHINED FINISH 0.8	NAME		DATE
FINISH	-		TNG LH DRAWN		270819
<small>UNLESS OTHERWISE SPECIFIED TOLERANCES ARE: X ±0.5 X.X ±0.1 X.XX ±0.05 ANGULAR TOLERANCES X ±1° X.X ±0.5°</small>		 EQUIPTTEST ENGINEERING PTE. LTD.		CHIN CHECKED	270819
		ALAN APPROVED		270819	
SIZE	A4	SCALE	N.T.S.	SHEET	5 OF 5
REF NO.			-		