

2

1

3

Proprietary and Confidential
Property of VA Innovation

3	SOCKET HEAD CAP SCREW M2.5x10L	SOCKET HEAD CAP SCREW M2.5x10L	4
2	DOWEL PIN 1.5x8L	DOWEL PIN	2
1	CS554-01-PW20	MAIN BLOCK	1
ITEM NO.	PART NUMBER	DESCRIPTION	QTY
<small>UNLESS OTHERWISE SPECIFIED 1. ALL DIMENSIONS IN MM. 2. GENERAL TOLERANCE USED : ±0.05 3. 3RD ANGLE PROJECTION</small>		 VA Innovation (S) Pte Ltd	
TREATMENT : FINISHING : 0.6 um		TITLE : TEST SOCKET for PW20	
DRAWN BY : SHAOHUI	SIZE A	MATERIAL :	DWG NO. : CS554-00-PW20 REV 0
DATE CREATED:	SCALE NTS	LAST DRAWN DATE: 21/01/2019	SHEET: 1 of 3 QTY :



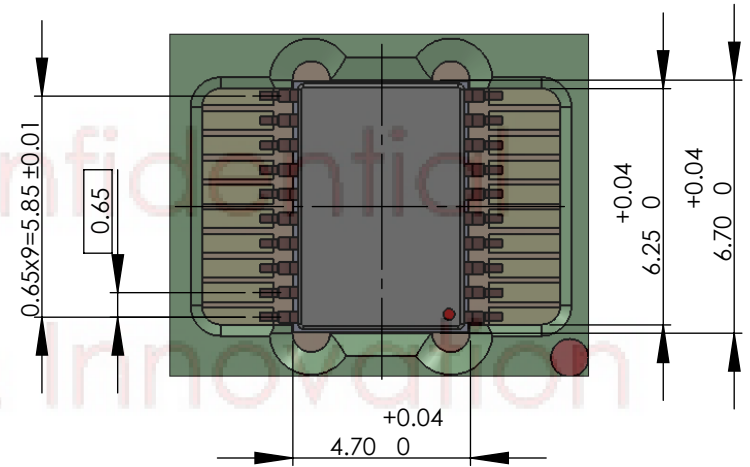
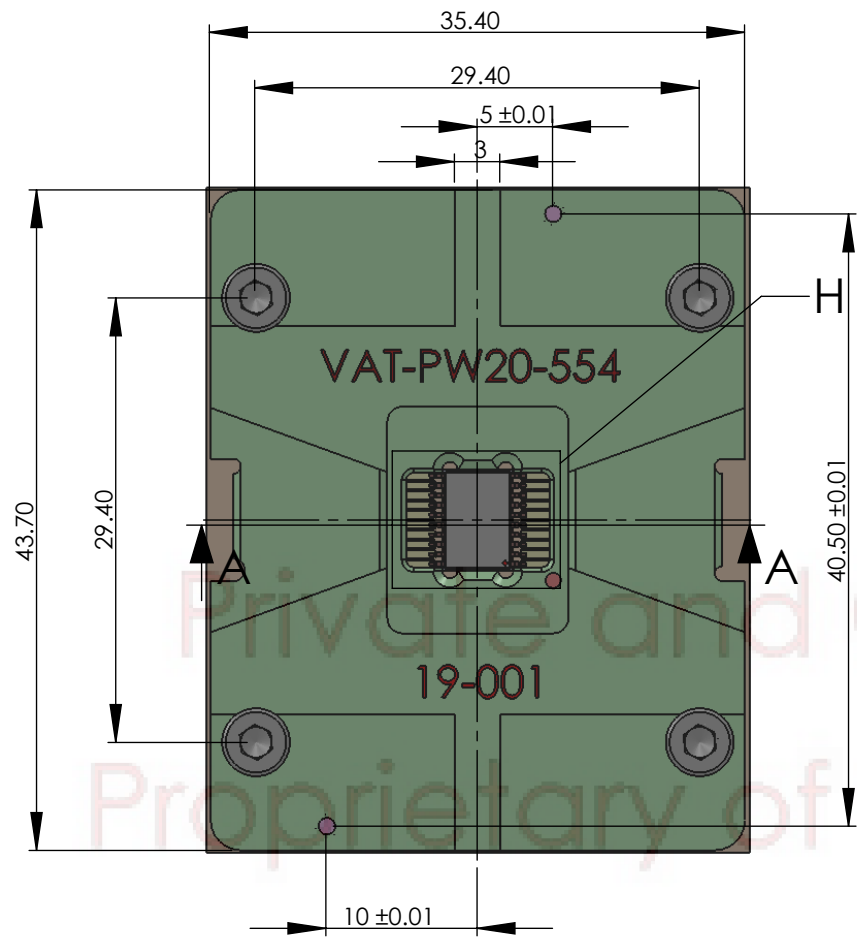

DETAIL H

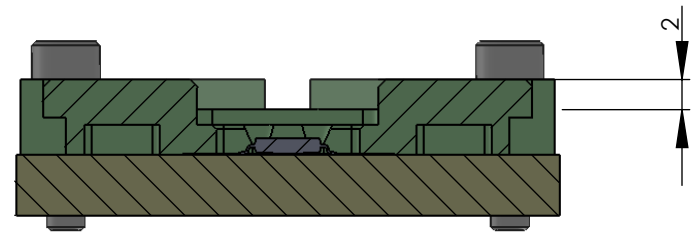

SECTION A-A
SCALE 2 : 1

UNLESS OTHERWISE SPECIFIED 1. ALL DIMENSIONS IN MM. 2. GENERAL TOLERANCE USED : ±0.05 3. 3RD ANGLE PROJECTION					 VA Innovation (S) Pte Ltd	
TREATMENT : FINISHING : 0.6 um		TITLE : TEST SOCKET for PW20				
DRAWN BY : SHAOHUI	SIZE A	MATERIAL :	DWG NO. CS554-00-PW20	REV 0		
DATE CREATED:	SCALE NTS	LAST DRAWN DATE: 21/01/2019	SHEET: 2 of 3	QTY :		

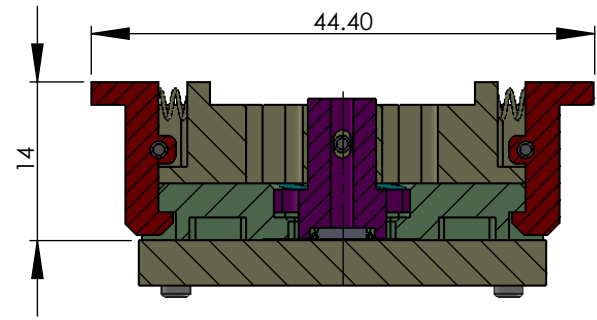
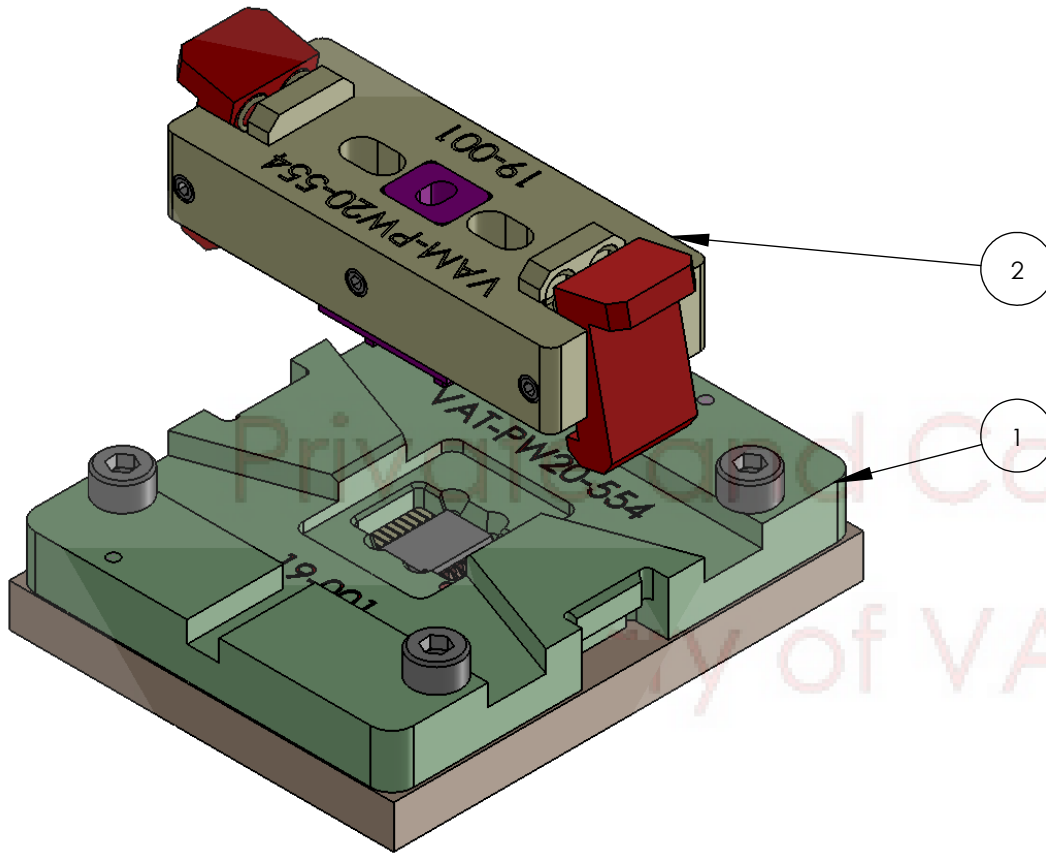

SECTION G-G
SCALE 1.5 : 1

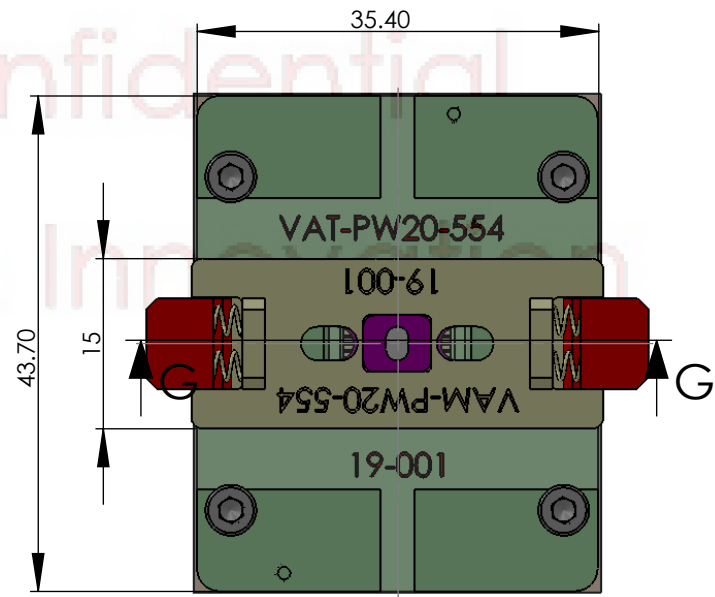

ITEM NO.	PART NUMBER	DESCRIPTION	QTY
2	ML554-00-PW20	MANUAL LID	1
1	CS554-00-PW20	TEST SOCKET for PW20	1

UNLESS OTHERWISE SPECIFIED
 1. ALL DIMENSIONS IN MM.
 2. GENERAL TOLERANCE USED : ±0.05
 3. 3RD ANGLE PROJECTION



VA Innovation (S) Pte Ltd

TREATMENT : FINISHING : 0.6 um	TITLE : TEST SOCKET for PW20 with MANUAL LID		
DRAWN BY : SHAOHUI	SIZE A	MATERIAL :	DWG NO. CML554-00-PW20
DATE CREATED :	SCALE NTS	LAST DRAWN DATE: 21/01/2019	REV 0
		SHEET: 3 of 3	QTY :

